

ONE FOR ALL

SUPPORT TV MOTORISE

WM7472

MANUEL D'UTILISATION



Besoin d'aide ?

Rendez-vous sur votre communauté <https://sav.darty.com>



UNIVERSAL TRIPOD TV STAND

QUICK INSTALLATION GUIDE

WM7471/7472



We're ready to assist with the installation



Support

Learn about One For All products, download manuals, watch instruction videos or get in contact with our Customer Service Team for personal assistance.

Support

Erfahren Sie mehr über unsere One For All Produkte, laden Sie Bedienungsanleitungen herunter, schauen Sie sich Anleitungsvideos an oder nehmen Sie Kontakt mit unserem Kundendienst auf, für eine persönliche Beratung.

Asistencia

Descubra todos los productos de One For All, descargue manuales, vea videos con instrucciones o póngase en contacto con nuestro Equipo de Asistencia Técnica para brindarle ayuda personalizada.

Supporte

Descobre os nossos produtos, Você pode ver videos de instrução, pode baixar manuais, ou entrar em contato com a nossa Equipe de Atendimento ao Cliente para obter assistência pessoal.

Supporto

La possibilità di avere più informazioni sui prodotti, scaricare manuali, guardare video d'istruzioni o contattare il nostro Servizio Clienti per assistenza personale.

Assistance

Apprenez-en plus sur les produits One For All, téléchargez les manuels, regardez des vidéos d'instructions ou prenez contact avec notre Service Clients pour une assistance personnelle.





Universal
200 x 200 | 300 x 200
300 x 300 | 400 x 200
400 x 300 | 400 x 400
600 x 400

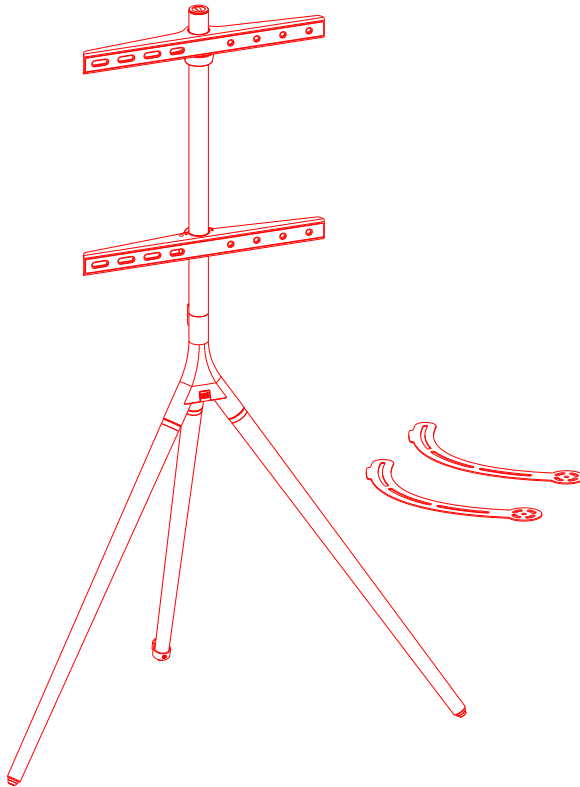

⚠ Safety Disclaimer

This product includes an anti-tip kit that must be used in conjunction with the product and will prevent the product from falling or tipping over. Please follow the enclosed information to properly install these safety accessories. In no event shall the Seller be liable for any direct, indirect, punitive, incidental, special consequential damages, to property or life, whatsoever arising out of or connected with the use or misuse of this product.

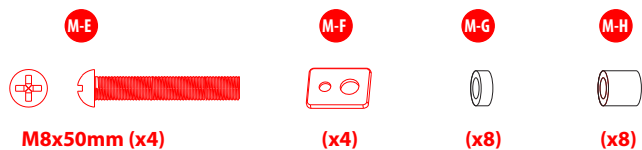
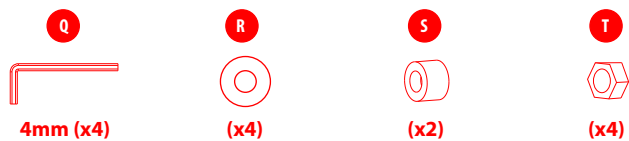
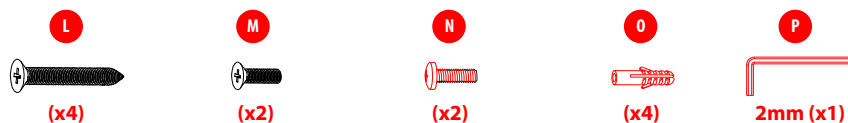
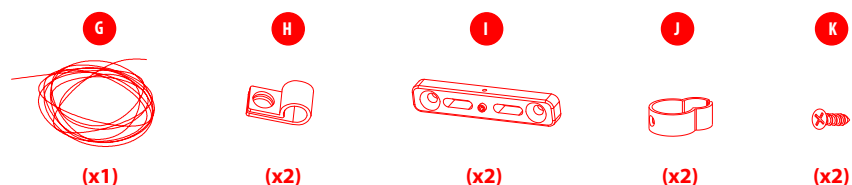
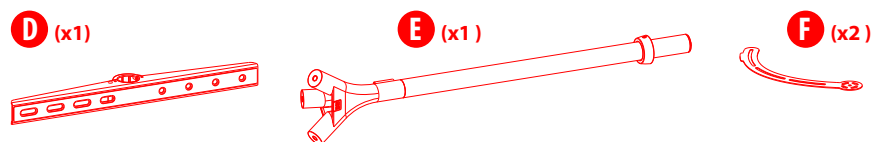
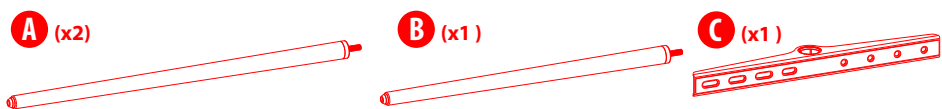

START



Please note that this product bears different weight load on glossy (such as wood) and normal floors (such as concrete).

1

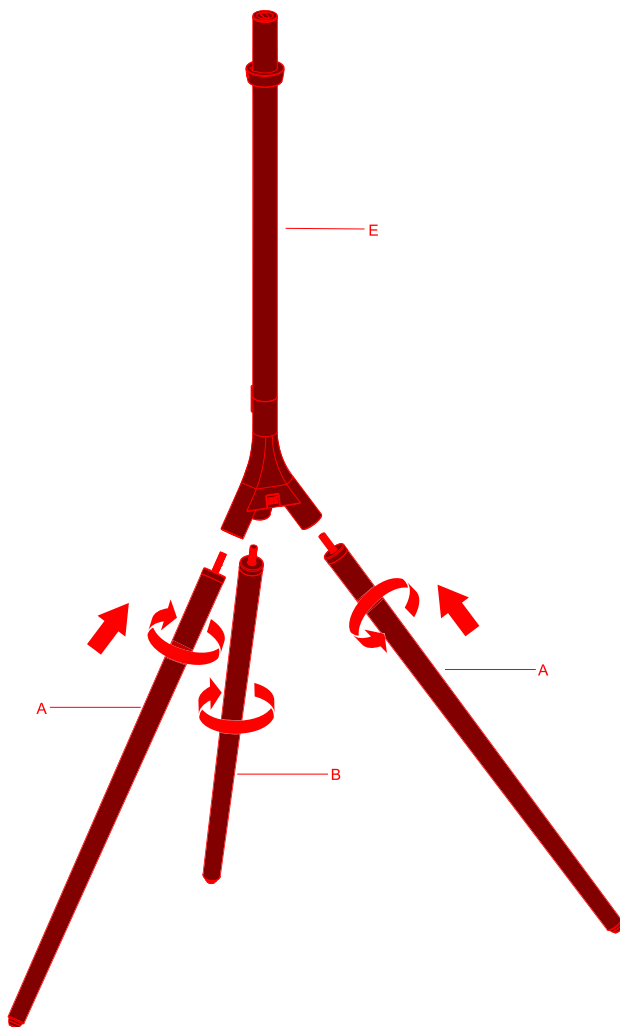

2

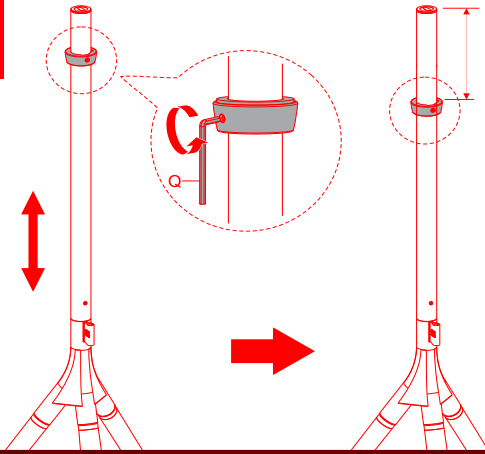

Recommended 50-150mm

Note:
Please secure the locking collar
before attaching the TV screen.



3

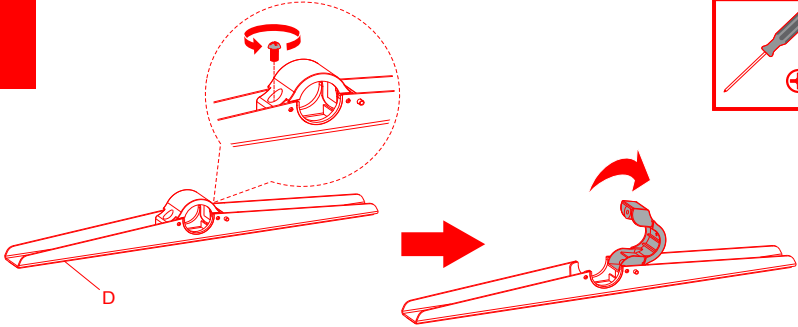

4

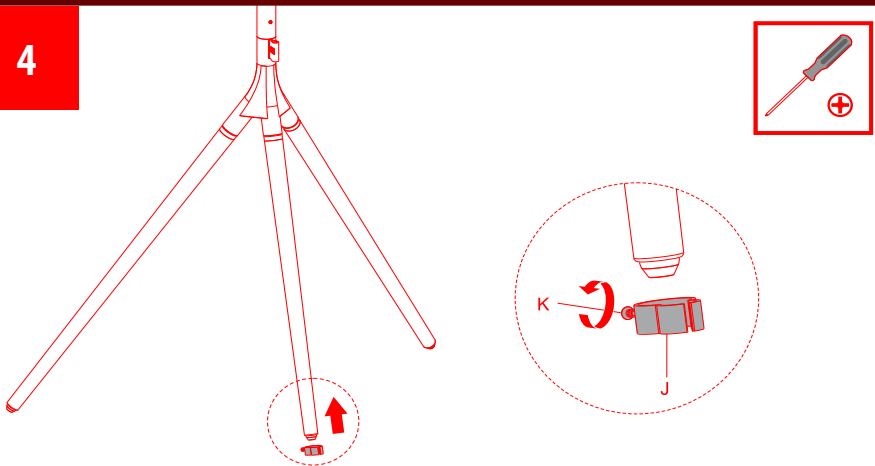

5a

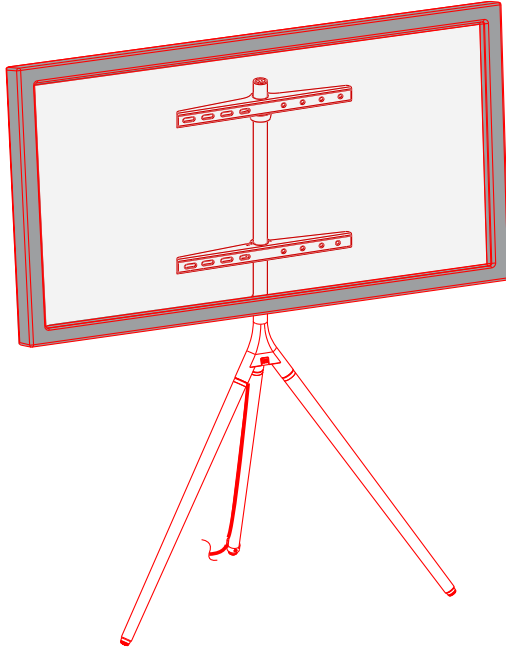

5a-1

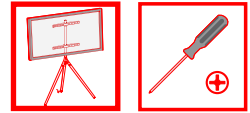

Make sure the cable clips(H) are attached to the upper bracket for the following security installation.

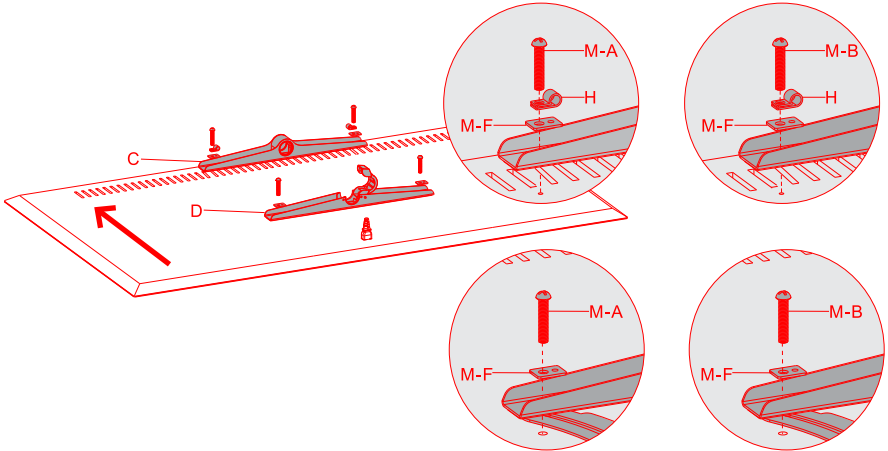

5a-2

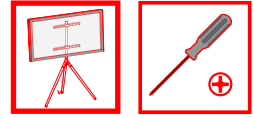

Make sure the cable clips(H) are attached to the upper bracket for the following security installation.

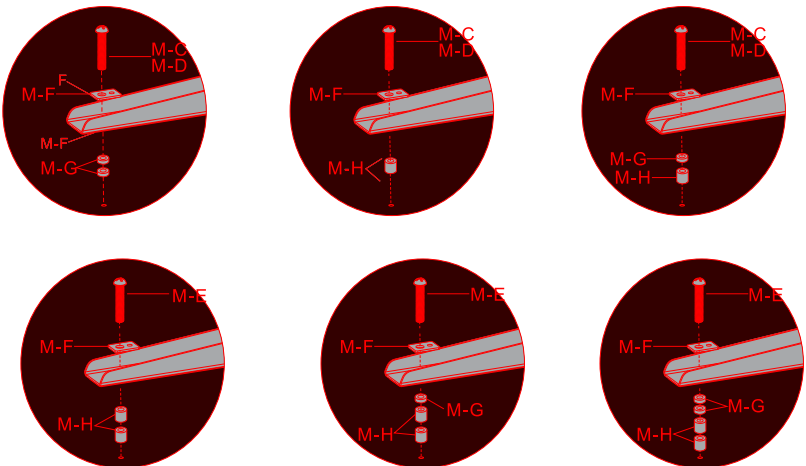
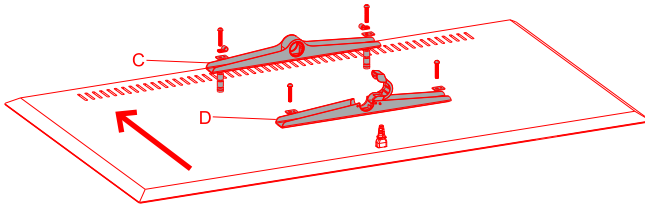
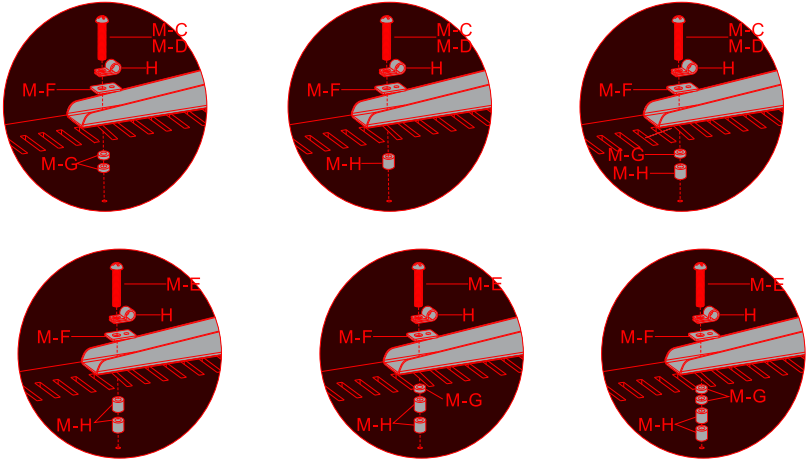

5a-3

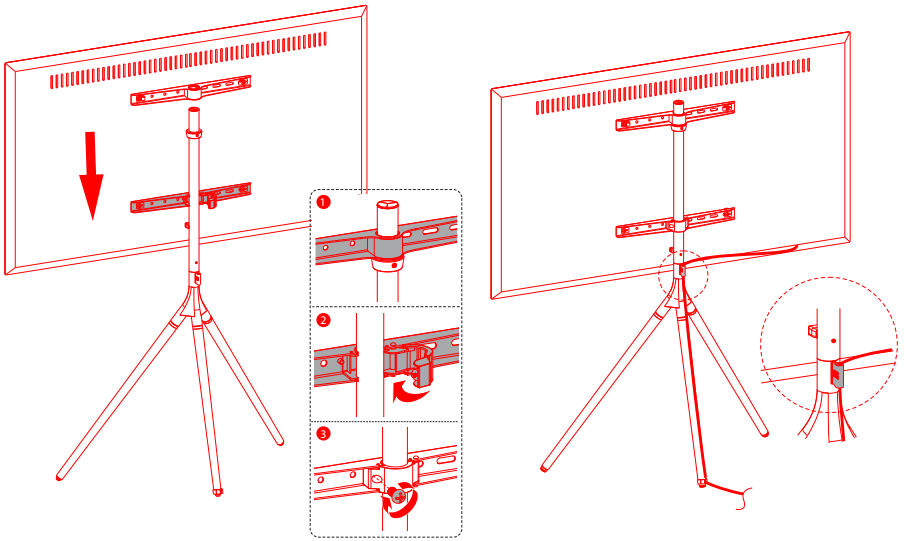

Please make sure the screen doesn't touch the aluminum plate.

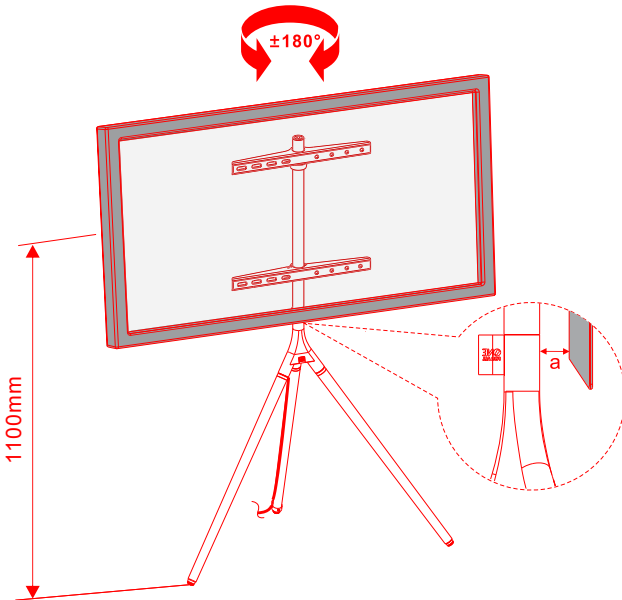

5a-4

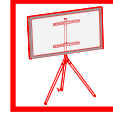

EXTRA To avoid TV falling, anti-fall wire rope should be installed.

G

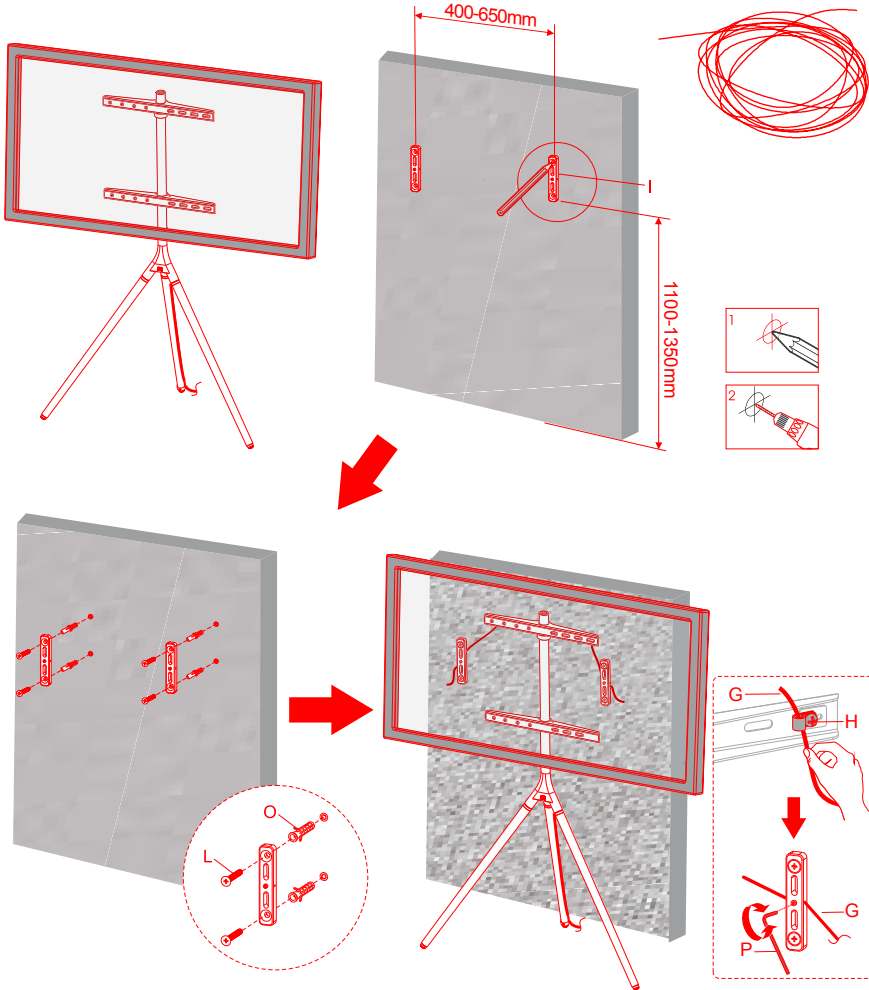

FINISH



5b

↑
SOUNDBAR

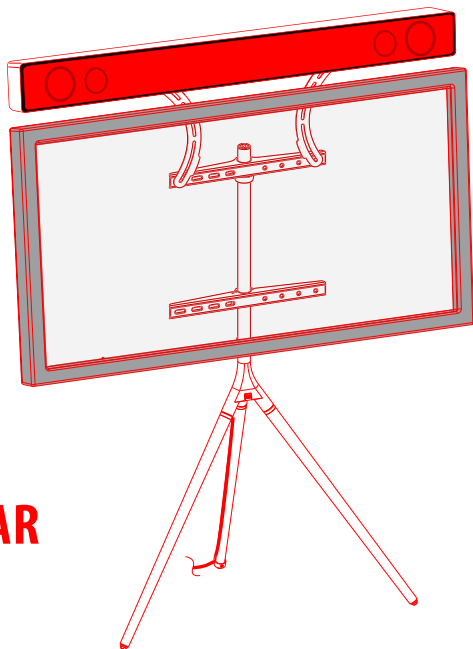

5b-1



Make sure the cable clips(H) are attached to the upper bracket for the following security installation.

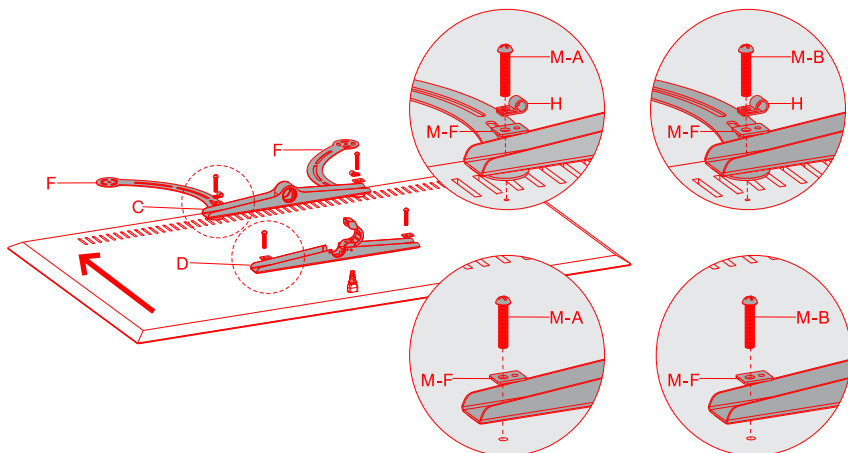

5b-2

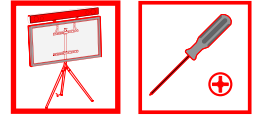

Make sure the cable clips(H) are attached to the upper bracket for the following security installation.

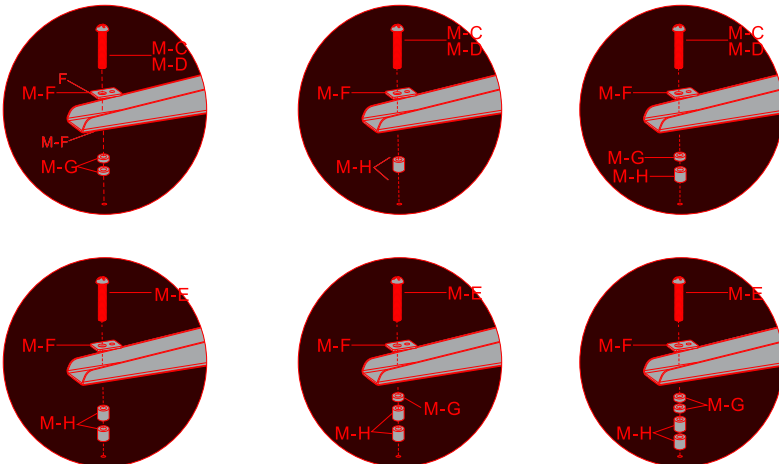
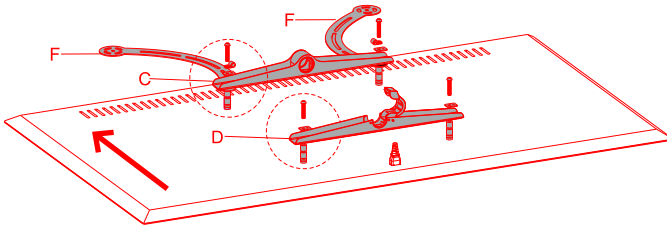
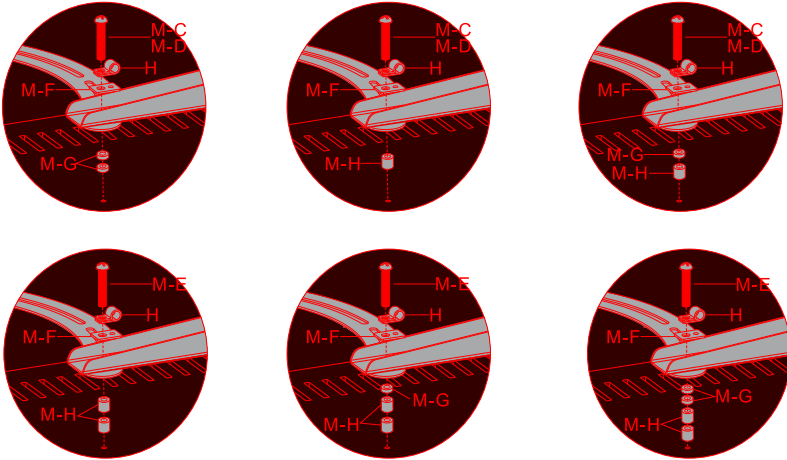

5b-3

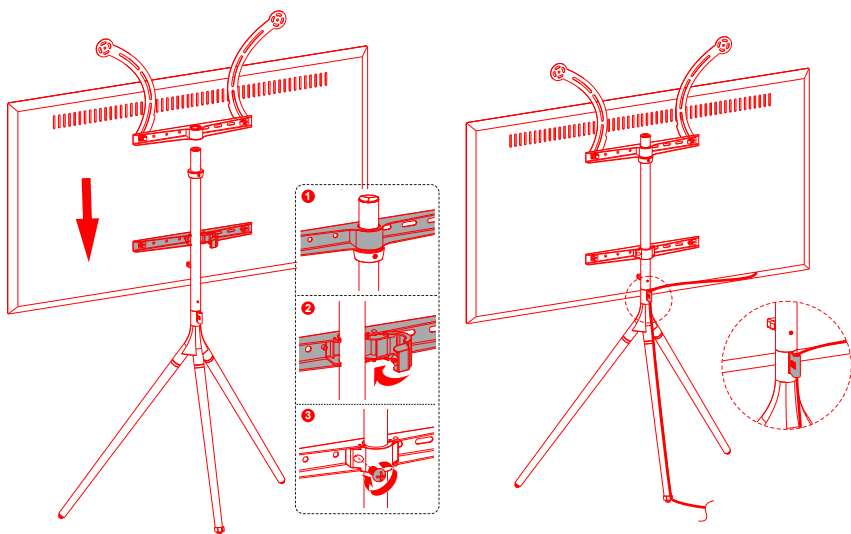

Please make sure the screen doesn't touch the aluminum plate.

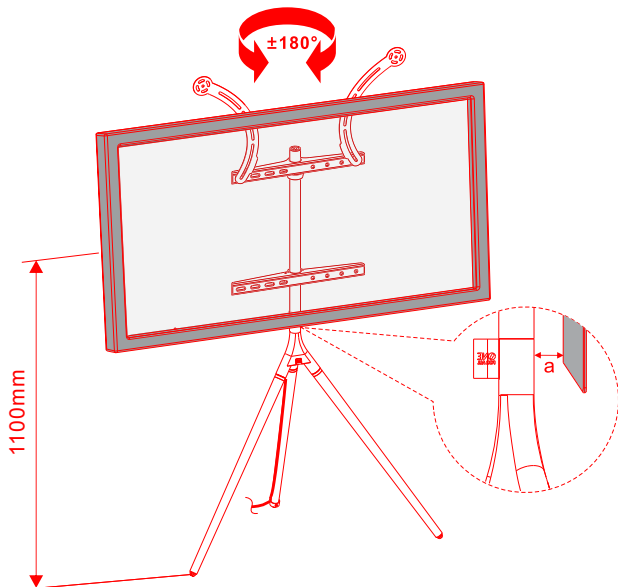

5b-4



EXTRA To avoid TV falling, anti-fall wire rope should be installed.

G

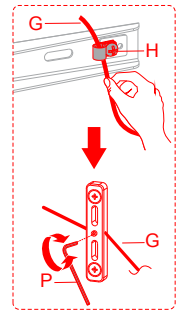
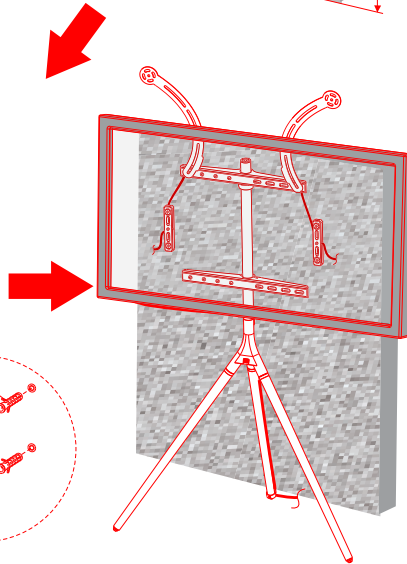
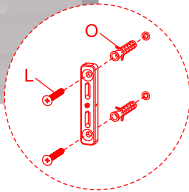
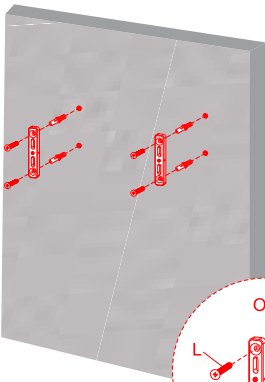
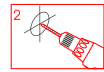
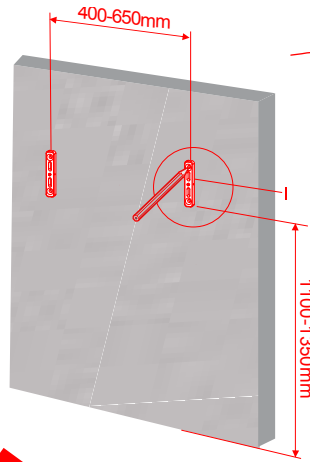
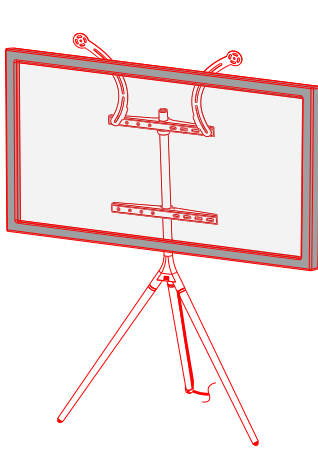

FINISH

5c

SOUNDBAR

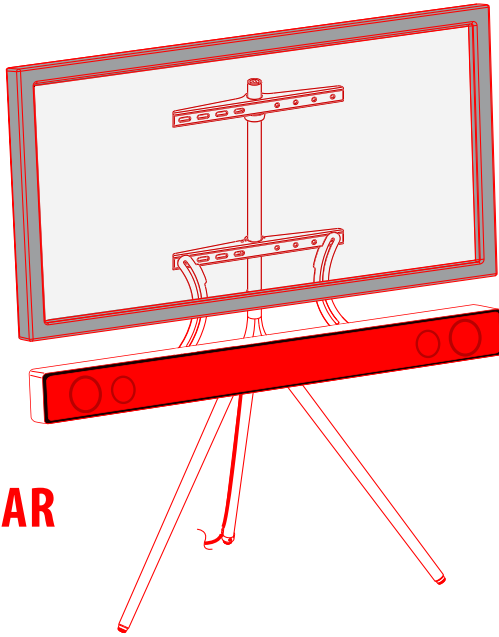

5c-1

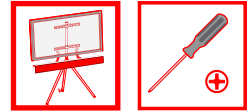

Make sure the cable clips(H) are attached to the upper bracket for the following security installation.

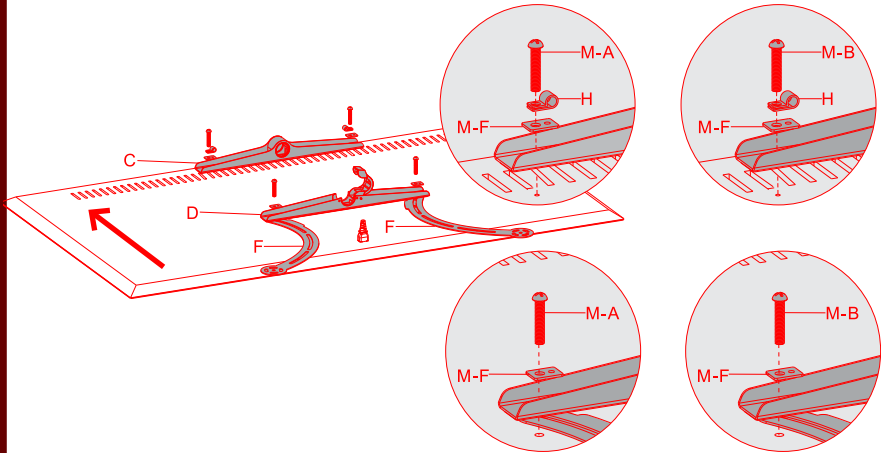

5c-2

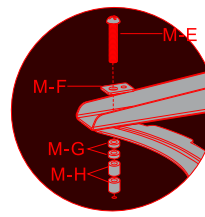
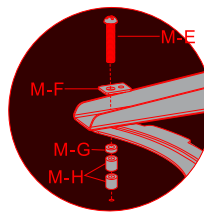
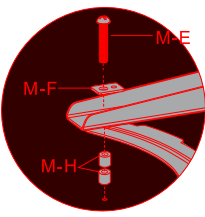
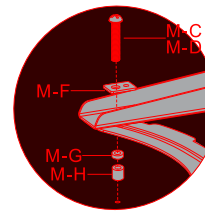
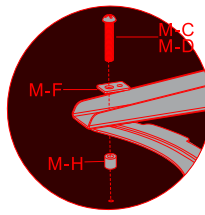
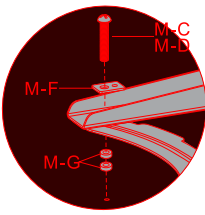
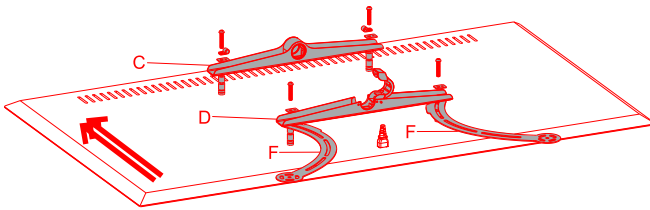
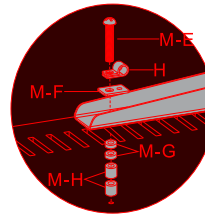
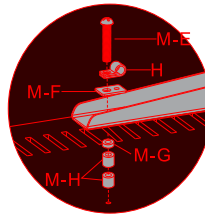
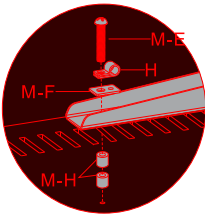
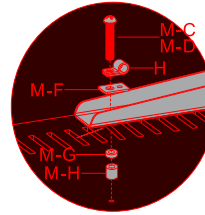
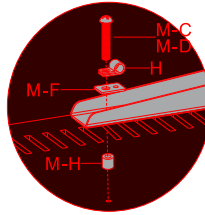
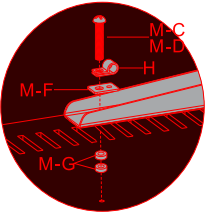

5c-3

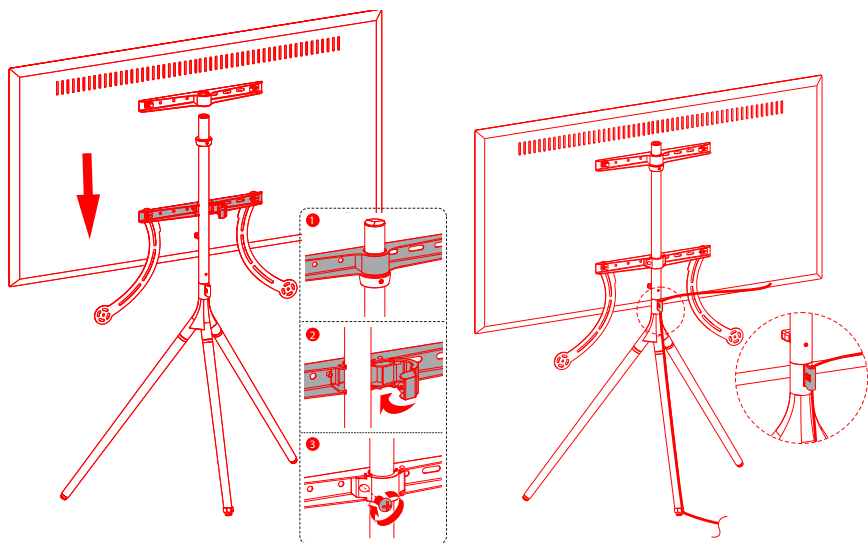

Please make sure the screen doesn't touch the aluminum plate.

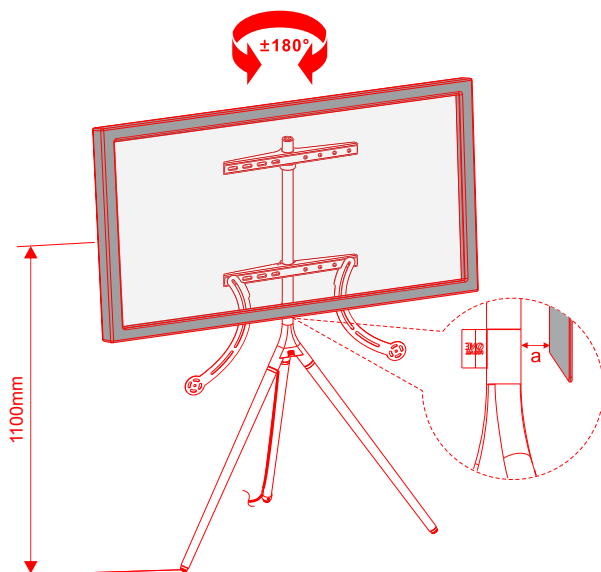

4c-4

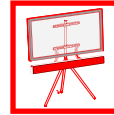
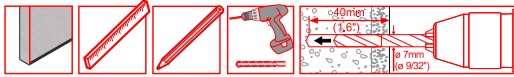

EXTRA

To avoid TV falling, anti-fall wire rope should be installed.

6

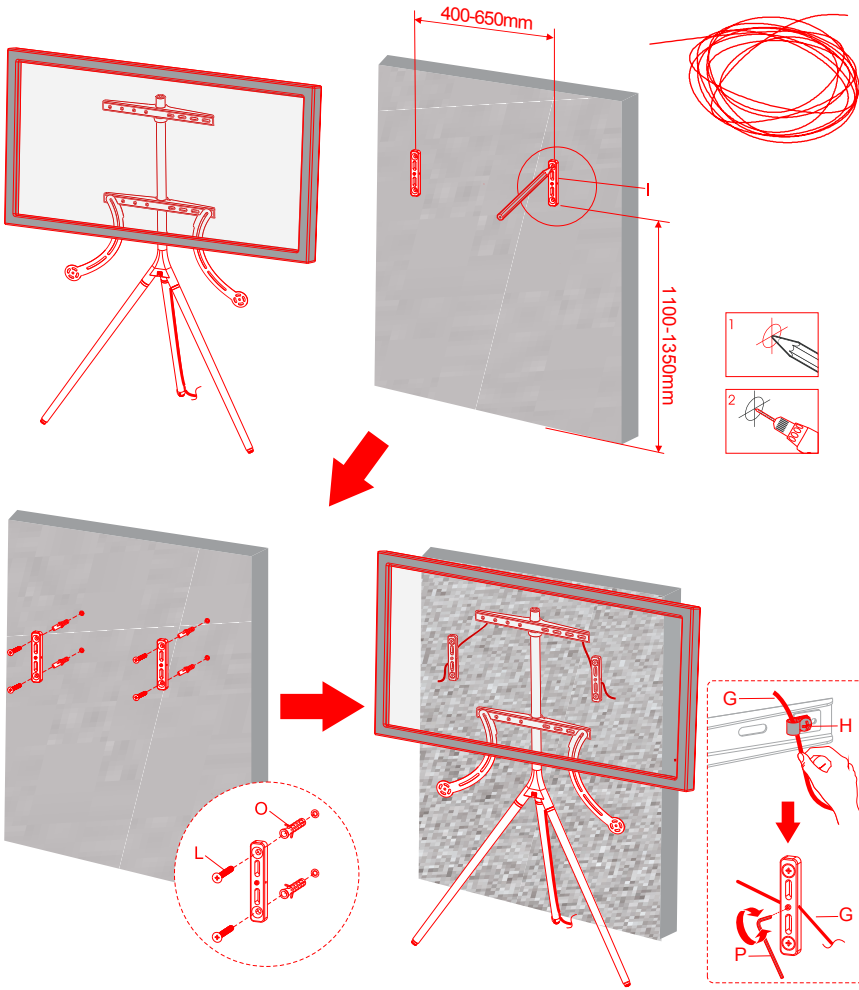

FINISH



GUARANTEE TERMS AND CONDITIONS

ENGLISH

Thank you for purchasing this ONE FOR ALL product! The product you now have in your possession is made of durable materials and is based on a design, every detail of which has been meticulously thought out. That is why ONE FOR ALL gives you a Life Time guarantee for defects in materials or manufacturing.

GUARANTEE TERMS AND CONDITIONS

1. ONE FOR ALL guarantees that if during the guarantee period of a product, faults arise due to defects in manufacturing and/or materials, it will, at its discretion, repair or if necessary replace the product, free of cost. A guarantee for normal wear and tear is hereby expressly excluded.
2. If the guarantee is invoked, the product should be sent to ONE FOR ALL together with the original purchase document (invoice, sales slip or cash receipt). The purchase document should clearly show the name of the supplier and the date of purchase.
3. ONE FOR ALL guarantee shall lapse in the following cases: - If the product has not been drilled, installed and used in accordance with the Instructions for Use; - If the product has been altered or repaired by a party other than ONE FOR ALL; - If a fault arises due to external causes (outside the product) such as for example lightning, water nuisance, fire, scuffing, exposure to extreme temperatures, weather conditions, solvents or acids, wrong use or negligence; - If the product is used for different equipment than is mentioned on or in the packing.

UNIVERSAL ELECTRONICS BV, COLOSSEUM 2, 7521 PT ENSCHEDE, THE NETHERLANDS

WARNING

Correct installation is extremely essential, and falls outside the scope of responsibility of ONE FOR ALL. The fastening material provided is exclusively intended for installation on walls made of solid wood, bricks, concrete or solid-wood columns with a maximum of 3 mm wall finishing. For walls made of other materials, for example hollow bricks, please consult your installer and/or specialist supplier. During installation, please also follow the instructions for installation and use of the apparatus to be installed/fixe (for example the LCD/LED/plasma screen).

DEUTSCH

Vielen Dank, dass Sie sich für dieses Produkt von ONE FOR ALL entschieden haben! Sie besitzen nun ein Produkt, das aus widerstandsfähigen Materialien besteht und dessen Konstruktion bis ins kleinste Detail durchdacht wurde. Deshalb gewährt Ihnen ONE FOR ALL eine lebenslange Garantie auf Material- oder Herstellungsfehler.

GARANTIEBEDINGUNGEN

1. Bei Mängeln, die während der Garantiezeit infolge von Herstellungs- und/oder Materialfehlern auftreten, garantiert ONE FOR ALL, dass sie das Produkt nach eigenem Ermessen kostenlos reparieren oder gegebenenfalls austauschen wird. Eine Garantie auf normale Abnutzung wird hiermit ausdrücklich ausgeschlossen.
2. Zur Geltendmachung der Garantie muss das Produkt zusammen mit dem Kaufbeleg im Original (Rechnung, Kassenbono oder Quittung) an ONE FOR ALL gesendet werden. Der Name des Händlers und das Kaufdatum müssen auf dem Kaufbeleg deutlich erkennbar sein.
3. Die Garantie von ONE FOR ALL erlischt in den folgenden Fällen: - Wenn das Produkt nicht den Gebrauchsanweisungen entsprechend gebohrt, montiert und verwendet wird; - Bei Eingriffen oder Reparaturen, die nicht von ONE FOR ALL durchgeführt wurden; - Wenn ein Mangel infolge äußerer Umstände (außerhalb des Produkts liegend) eintritt, zum Beispiel durch Blitzschlag, Einwirken von Wasser, Feuer, Kratzern, Aussetzen gegenüber extremen Temperaturen, Witterungsbedingungen, Lösungsmittel oder Säuren, falsche Verwendung oder Fahrlässigkeit; - Wenn das Produkt für Geräte verwendet wird, die nicht auf oder in der Verpackung angegeben sind.

UNIVERSAL ELECTRONICS BV, COLOSSEUM 2, 7521 PT ENSCHEDE, NIEDERLANDE

WARNING

Die korrekte Montage ist extrem wichtig und liegt nicht im Verantwortungsbereich von ONE FOR ALL. Das mitgelieferte Befestigungsmaterial ist ausschließlich für die Montage an Wänden vorgesehen, die aus Massivholz, Ziegelsteinen, Beton oder Massivholzstützen bestehen, mit einer maximal 3 mm starken Putzschicht. Sind die Wände aus anderen Materialien, zum Beispiel aus Holzziegeln, wenden Sie sich bitte an den Monteur oder Ihren Fachhändler. Bei der Montage sind auch die Montage- und Gebrauchsanweisungen des Gerätes zu befolgen, das montiert/angebracht werden soll (z. B. der LCD-/LED-/Plasma-Bildschirm).

FRANÇAIS

Merci d'avoir fait l'acquisition de ce produit ONE FOR ALL ! Le produit que vous avez maintenant en votre possession est fabriqué avec des matériaux durables et sa conception a été pensée dans les moindres détails. C'est pourquoi ONE FOR ALL vous propose une garantie à vie contre tout vice de fabrication ou de matériaux.

CONDITIONS GÉNÉRALES DE GARANTIE

1. La société ONE FOR ALL vous garantit que, en cas de défaillance survenant durant la période de garantie du produit du fait d'un vice de fabrication et/ou d'un défaut de matériau, elle procédera gratuitement, à sa discrétion, à la réparation ou, si nécessaire, au remplacement du produit. Les problèmes dus à une usure normale du produit sont expressément exclus de la présente garantie.
2. Dans le cas où la garantie est invoquée, le produit doit être renvoyé à ONE FOR ALL accompagné de l'original de la preuve d'achat (facture, reçu de vente ou ticket de caisse). La preuve d'achat doit clairement indiquer le nom du revendeur et la date d'achat.
3. La garantie ONE FOR ALL sera considérée caduque dans les cas suivants: - Si le produit n'a pas été percé, installé et utilisé conformément aux instructions d'utilisation fournies; - Si le produit a été modifié ou réparé par un tiers autre que ONE FOR ALL; - Si un problème survient du fait d'une cause extérieure au produit, par exemple en cas de foudre, de dégât des eaux, d'incendie, d'aérafure, d'exposition à des températures extrêmes, aux conditions météorologiques, à des solvants ou acides, d'utilisation incorrecte ou de négligence; - Si le produit est utilisé pour un équipement différent de celui indiqué sur ou dans l'emballage.

UNIVERSAL ELECTRONICS BV, COLOSSEUM 2, 7521 PT ENSCHEDE, PAYS-BAS

AVERTISSEMENT

Une installation correcte est essentielle et n'est pas de la responsabilité de ONE FOR ALL. Les accessoires de fixation fournis sont exclusivement destinés à l'installation du produit sur des murs faits de bois massif, de briques pleines ou de béton, ou sur des colonnes en bois massif, avec un revêtement d'une épaisseur maximum de 3 mm. Pour les murs et cloisons fabriqués dans d'autres matériaux, par exemple des briques creuses, veuillez consulter votre installateur et/ou un spécialiste. Lors de l'installation, veuillez respecter les instructions d'installation et d'utilisation de l'appareil à installer/fixer (par exemple un écran LCD/LED/plasma).

HRVATSKI

Zahvaljujemo vam na kupnji proizvoda tvrtke ONE FOR ALL! Proizvod koji je sada u vašem vlasništvu izrađen je od izdržljivih materijala i prekrasno je dizajniran - svi su detalji posebno osmišljeni. Stoga tvrtka ONE FOR ALL nudi doživotno jamstvo na nedostatke u materijalu ili izradi.

JAMSTVENI UVJETI

1. Tvrtka ONE FOR ALL jamči da će dok traje jamstvo proizvoda sve nedostatke u proizvodnji i/ili materijalu, prema vlastitom nahođenju, otkloniti ili, ako je potrebno, zamijeniti proizvod bez ikakvih dodatnih troškova. Jamstvo za uobičajeno trošenje i habanje proizvoda ovom se izjavom izričito isključuje.
2. Za ostvarivanje prava jamstva proizvod je potrebno poslati tvrtki ONE FOR ALL zajedno sa svim originalnim dokumentima primljenim prilikom kupnje (račun, potvrda plaćanja kreditnom karticom, virman). Primljeni dokumenti moraju sadržavati naziv dobavljača i datum kupnje.
3. Jamstvo tvrtke ONE FOR ALL prestaje važiti u sljedećim slučajevima: - Ako proizvod nije namješten, postavljen ili korišten prema uputama za uporabu; - Ako je proizvod preuređivala ili popravljala osoba koju nije ovlastila tvrtka ONE FOR ALL; - Ako je kvar nastao zbog vanjskih uzroka (izvan proizvoda) kao što su gmmljavina, djelovanje vode ili vatre, habanje, izlaganje ekstremnim temperaturama, vremenskim uvjetima, otapalima ili kiselinama, neispravno korištenje ili nemar; - Ako je proizvod korišten za svrhu koja nije navedena na pakiranju.

UNIVERSAL ELECTRONICS BV, COLOSSEUM 2, 7521 PT ENSCHEDE, NIZOZEMSKA**UPOZORENJE**

Ispravno postavljanje izuzetno je važno i ne spada u odgovornosti tvrtke ONE FOR ALL. Osiguran materijal za pričvršćivanje namijenjen je isključivo ugradnji na zidove izrađene od masivnog drva, cigle, betona ili drva sa zidnom stjenkom od najviše 3 mm. Za zidove od drugih materijala, na primjer suplje cigle, molimo obratite se svojem monteru ili dobavljaču. Tijekom postavljanja također je potrebno pratiti upute za ugradnju i korištenje uređaja koji postavljate/montirate (na primjer LCD/LED/plazma ekrana).